

Cold work installation : save time and costs

Modification work

Offshore installations are periodically modified or upgraded which inevitably requires additional pipe work, valves etc. The operator needs to minimise downtime and costs during those periods. A report from DNV states the SPO compact flange to be as reliable as a 12m length of girth welded pipe. This means the prefabricated and cold work assembled solution is an acceptable technical alternative (and cheaper option) to hot work habitat welding of joints. Without the habitat the whole installation must shut down during the hot work process.

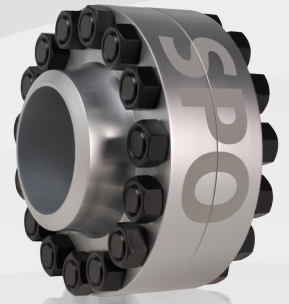

Installation of SPO CF spools onboard Sleipner R platform

Requirement for SPO CF solution

- Spools pre-fabricated and tested onshore.
- Installation of spools and assembly of flanges offshore (cold work permit)



Typical welding habitat

Requirement for Habitat solution

- Habitat to be designed to fit each location
- Habitat fabricated from fire resistant materials.
- Installation of habitat and ventilation system.
- Risk analysis of Habitat environment.
- Welding operation (hot work permit)
- Preservation of pipe work.
- Removal of habitat.

How to save time and money ?

By using prefabricated pipe spools with SPO compact flanges.



Cost comparison welding vs SPO CF

(example 8" line, 150#, Sch 20, LT carbon steel)

Welding in habitat	
Construction of habitat	80,000 NOK
Hire of habitat 1 day	2,000 NOK
Habitat crew	5,000 NOK
Offshore weld incl. NDT	9,600 NOK
Pressure test per weld	5,000 NOK
Mobilization and disassembly of habitat	4,000 NOK
TOTAL	105,600 NOK



Pair of SPO compact flanges	
One pair of SPO CF incl. sealing and bolts	12,000 NOK
Onshore welding of 2 welds incl. NDT	10,000 NOK
Pressure test of 2 welds, i.e. one spool	10,000 NOK
Offshore assembly	9,600 NOK
TOTAL	41,600 NOK

Cold work installation : save time and costs

Some impressive facts on using prefabricated SPO spoos

- Shut down period reduced from 22 days to 8 days !
- Offshore work reduced by 25.000 hrs and onshore prefabrication increased by 15.000 hrs.
- Improved safety during installation (absence or a minimum of hot work).
- SPO flanged connections will make future maintenance easy.



Tremendous time saving can be achieved during shutdown periods!

For Example - the tie in of the pipeline from Ormen Lange to Sleipner R platform where the achieved downtime saving was 14 days. This was as a result of; offshore installation while platform was in operation; no welding required when installing prefabricated equipment and SPO Compact Flanges ready to be bolted on! Achievement: Significantly reduced duration of shut down period and costs by using SPO compact flanges, as well as improving safety by eliminating offshore welding !

As reliable as a welded connection

DNV (Det Norske Veritas) considers the SPO CF to be in the magnitude as a welded connection with respect to leakage probability (stated in DNV report no/DNV Reg. No. : /12FQG2F-6 Rev 01,2010-03-12). This means that the SPO CF can be considered as being as reliable as a welded connection.

Standard offshore flanges on the other hand (chart left hand side) are regarded as a potential leak source and is consequently avoided at certain areas at an oil & gas installation. Operators have taken advantage of the high reliability provided by the SPO Compact Flange to use flanged connections in hazardous areas, and consequently achieved significant savings.

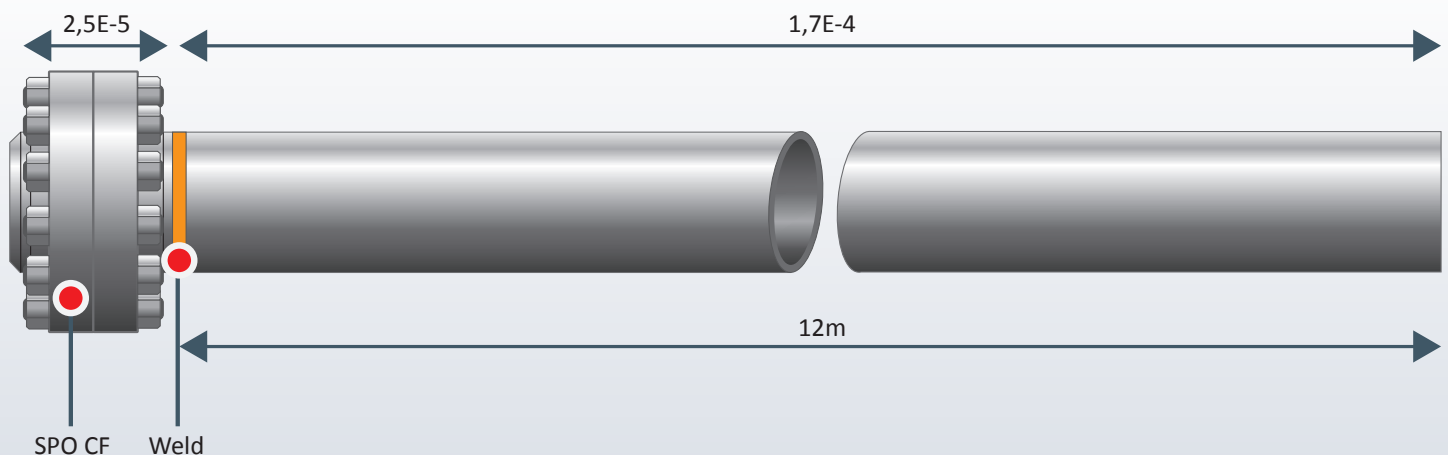
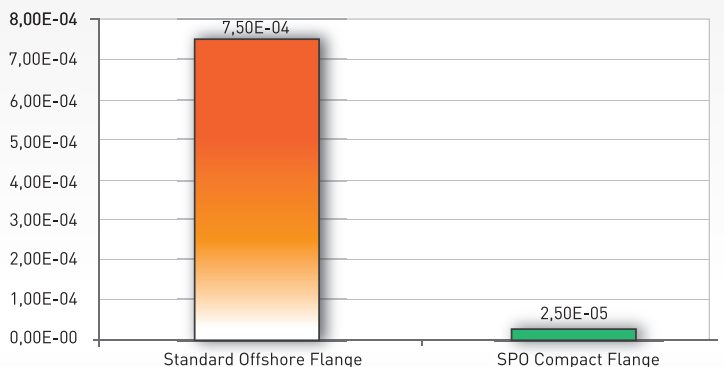

Leakage rate probability per year of a flange compared to piping and girth weld

Test Setup	Small / Medium
Compact Flange	2.5 - 10 ⁻⁵
Standard Offshore Flange	7.5 - 10 ⁻⁴
12m piping including one girth weld	1.7 - 10 ⁻⁴